

SPARBUCH

Bestseller für die Zerspanung 08.2023



Inhalt:

Bohrstangen, Wendeschneidplatten,
Gewindedreher, etc.

Inhaltsverzeichnis:









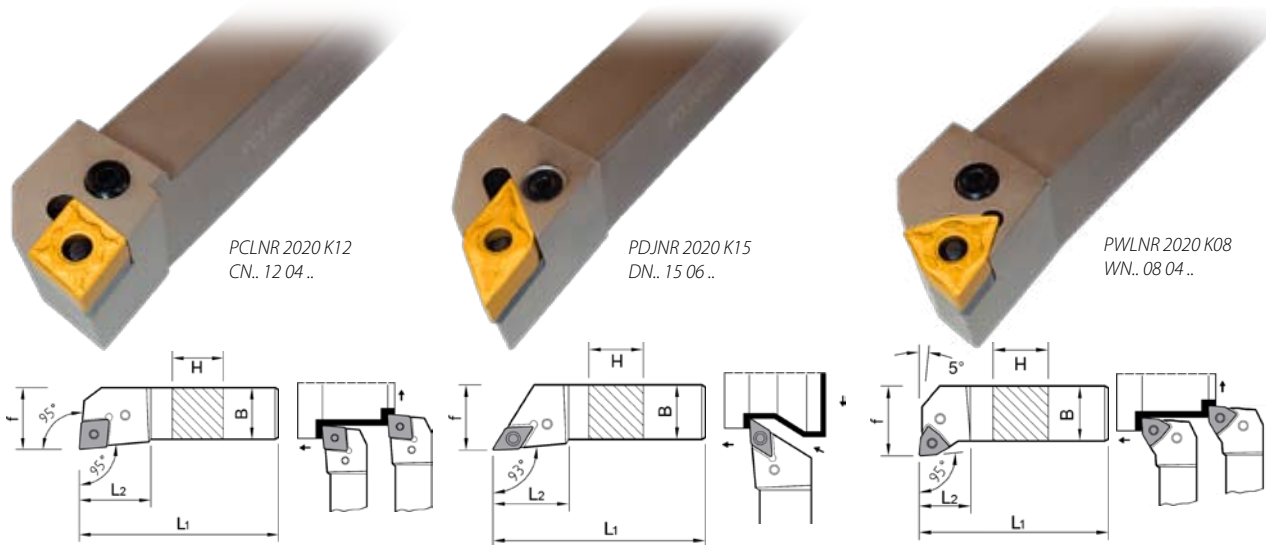











	Seite
Außendrehen, negativ	3
Außendrehen, positiv	4
HM - Bohrstangen mit Innenkühlung	5
Abgesetzte Stahlbohrstangen	6
CB - Bohrstangen, reduzieren Schwingungen	7
Microbore, Kleinstbohrstangen	8
Aluminium Wendeplatten zum Drehen	9-10
Aluminium Wendeplatten zum Fräsen	10

Außendrehen, negativ

Bezeichnung	new!		-JBM	-MD	-S30
			TWS 7225 (M25/P30C) Stahl / Niro	TP 4025+ (P25/M20C) Stahl	TM 5125 (M25C) Niro
					
			EUR/Stück Piece	EUR/Stück Piece	EUR/Stück Piece
CNMG 12 04 04		7,40	6,10	-	
12 04 08				6,10	
DNMG 15 06 04		8,60	8,30	-	
15 06 08				8,30	
VNMG 16 04 04		8,50	-	8,00	
16 04 08					
WNMG 06 04 08		-	5,50	5,50	
08 04 04		7,00	6,50	-	
08 04 08				6,50	

PCLN- / PDJN- / PWLN-



Bezeichnung	Maße [mm]					Ersatzteile					EUR/Stück Piece	
	H	B	L ₁	L ₂	f						R	L
PCLNR/L 1616 H12	16	16	100	20	20						63,00	63,00
2020 K12	20	20	125	22	25	9,10	6,55	7,25	2,60	48.12.603 (SW3) 1,75	63,00	63,00
2525 M12	25	25	150	28	32						66,00	66,00
PDJNR/L 2020 K15	20	20	125	35	25						74,00	74,00
2525 M15	25	25	150	35	32	9,10	6,55	7,65	2,60	48.12.603 (SW3) 1,75	74,00	74,00
PWLN/L 2020 K08	20	20	125	26	25						74,00	74,00
2525 M08	25	25	150	26	32	9,10	6,55	9,10	2,60	48.12.603 (SW3) 1,75	74,00	74,00

Außendreher, positiv

Bezeichnung	-JTM	-MD	-M30	
	TWS 7225 (M25/P30C) Stahl / Niro	TP 4025+ (P25/M20C) Stahl	TM 5125 (M25C) Niro	TP 3120 (P25C) Stahl
				
	EUR/Stück Piece	EUR/Stück Piece	EUR/Stück Piece	EUR/Stück Piece
CCMT 06 02 04	5,30	5,00	5,00	5,00
06 02 08		(5,00)	-	
09 T3 04	6,30	6,00	6,00	6,00
09 T3 08		(6,00)		
12 04 04	7,40	7,00	7,00	(7,00)
12 04 08				7,00
DCMT 07 02 04	5,30	4,80	4,80	4,80
07 02 08		-		
11 T3 04	6,50	6,00	6,00	6,00
11 T3 08				
VBMT 16 04 04	8,50	(8,00)	8,00	8,00
16 04 08				
VCMT 11 03 04	7,50	7,00	-	-
11 03 08		-		
16 04 04	8,50	8,00	8,00	8,00
16 04 08				

SCLC-

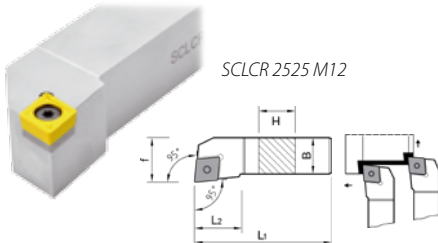



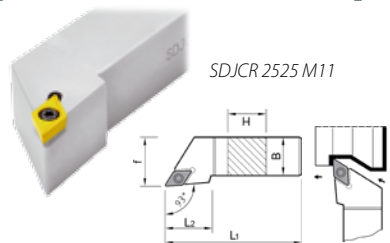

SDJC-

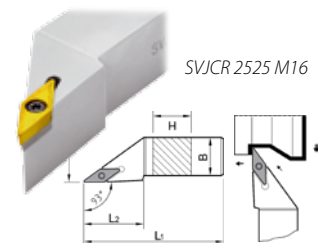

SVJC-



Bezeichnung	Maße [mm]					Ersatzteile				EUR/Stück Piece				
	H	B	L ₁	L ₂	f					R	L			
SCLCR/L 1616 H09	16	16	100	16	20	48.13.102 4,70	48.13.201 16,00	48.13.301 6,95	56.33.613 (T15) 4,70	42,00	42,00			
2020 K09	20	20	125	25	25					45,00	45,00			
2020 K12	20	20	125	25	25					48.13.103 4,70	48.13.202 16,00	48.13.302 6,45	45,00	45,00
2525 M12	25	25	150	25	32					47,00	47,00			
SDJCR/L 1616 H11	16	16	100	24	20	48.13.102 4,70	48.13.203 10,55	48.13.301 6,95	56.33.613 (T15) 4,70	42,00	42,00			
2020 K11	20	20	125	24	25					45,00	45,00			
2525 M11	25	25	150	29	32					47,00	47,00			
SVJCR/L 1616 H11	16	16	100	25	20	48.24.107 4,70	-	-	56.33.612 (T08) 4,70	39,00	39,00			
2020 K11	20	20	125	32	25	48.13.102 4,70	48.13.209 10,80	48.13.301 6,95	56.33.613 (T15) 4,70	45,00	(45,00)			
2020 K16	20	20	125	29,5	25					45,00	45,00			
2525 M16	25	25	150	32,5	32					47,00	47,00			

Innendrehen

HM Bohrstangen mit Innenkühlung



Set
E-SDUCR/L 07
für / for DC ... 07 02 ...

- mit Innenkühlung
- schwingungsarm
- mit dachförmiger Lötung für höchste Stabilität

WSP nicht im Lieferumfang







Set
E-SCLCR/L 06
für / for CC ... 06 02 ...

- mit Innenkühlung
- schwingungsarm
- mit dachförmiger Lötung für höchste Stabilität

WSP nicht im Lieferumfang

Bezeichnung / Set	bestehend aus:	EUR/Set
Set E-SCLCR/L 06	1X E08K SCLCR/L 06 1X E10M SCLCR/L 06 1X E12Q SCLCR/L 06	513,-
Set E-SDUCR/L 07	1X E10M SDUCR/L 07 1X E12Q SDUCR/L 07	374,-

Bezeichnung / Einzelwerkzeug	Ges.-Länge (mm)	Dmin (mm)	Ersatzteile				EUR/Stück Piece
							
E08K SCLCR/L 06	125	11					154,50
E10M SCLCR/L 06	150	14	56.33.104 5,70	-	-	56.33.612 (T08) 4,70	180,00
E12Q SCLCR/L 06	180	17					235,00
E16R SCLCR/L 09	200	21	48.24.108 4,70	-	-	56.33.613 (T15) 4,70	359,00
E20S SCLCR/L 09	250	25					558,00
E10M SDUCR/L 07	150	14	56.33.104 5,70	-	-	56.33.612 (T08) 4,70	180,00
E12Q SDUCR/L 07	180	17					235,00
E16R SDUCR/L 07	200	21					359,00
E20S SDUCR/L 11	250	25	48.24.108 4,70	-	-	56.33.613 (T15) 4,70	558,00

Innendrehen

Abgesetzte Stahlbohrstangen mit Innenkühlung



Set
A0812 SDUCR/L
 für / for DC... 07 02...
 bestehend aus
 1x A 0810 H SDUCR/L 07
 1x A 1012 K SDUCR/L 07
 1x A 1216 M SDUCR/L 07





WSP nicht im Lieferumfang



Set
A0612 SCLCR/L
 für / for CC ... 06 02...
 bestehend aus
 1x A 0608 H SCLCR/L 06
 1x A 0810 J SCLCR/L 06
 1x A 1012 K SCLCR/L 06
 1x A 1216 M SCLCR/L 06

WSP nicht im Lieferumfang

Bezeichnung / Set	bestehend aus:	EUR/Set
Set A0612 SCLCR/L 06	1X A 0608 H SCLCR/L 06 1X A 0810 J SCLCR/L 06 1X A 1012 K SCLCR/L 06 1X A 1216 M SCLCR/L 06	171,-
Set A0812 SDUCR/L 07	1X A 0810 H SDUCR/L 07 1X A 1012 K SDUCR/L 07 1X A 1216 M SDUCR/L 07	131,-

Bezeichnung / Einzelwerkzeug	Maße [mm]							Ersatzteile				EUR/ Stück Piece
	D _{min}	D ₁	H	L ₁	L ₂	f						
A0608H SCLCR/L 06	8	8	7	100	25	4.50	48.24.107 4,70	-	-	56.33.612 (T08) 4,70	44,00	
A0810J SCLCR/L 06	11	10	9	110	32	6.00					44,00	
A1012K SCLCR/L 06	13	12	11	125	38	7.00					46,00	
A1216M SCLCR/L 06	16	16	15	150	50	9.00					55,00	
A0810H SDUCR/L 07	12.5	10	9	100	22	7.00	48.24.107 4,70	-	-	56.33.612 (T08) 4,70	44,00	
A1012K SDUCR/L 07	15.5	12	11	125	28	9.00					46,00	
A1216M SDUCR/L 07	19.5	16	15	150	36	11.00					55,00	

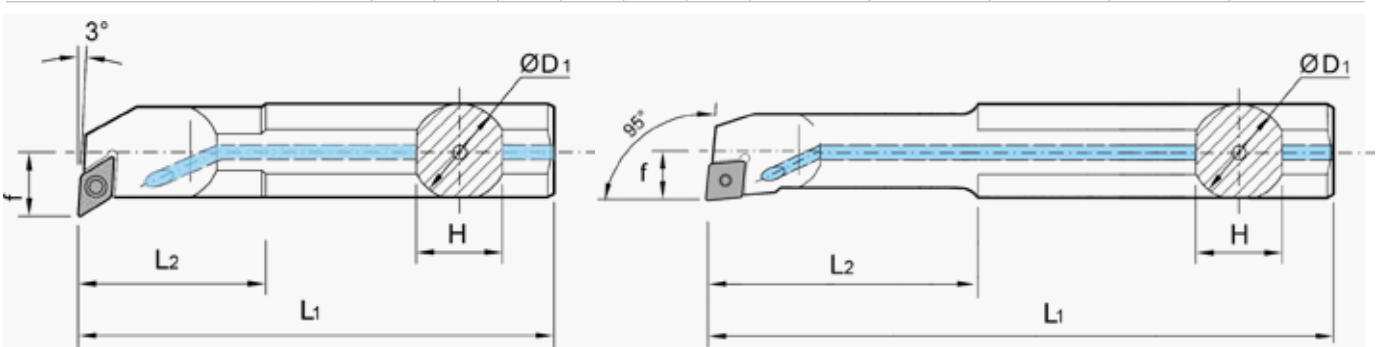

Innendrehen

CB-Bohrstangen Bars

- Verbesserte Spanabfuhr durch zusätzliche Spankammern.
- CB-Bohrstangen reduzieren Schwingungen und sorgen für perfekte Oberflächen.

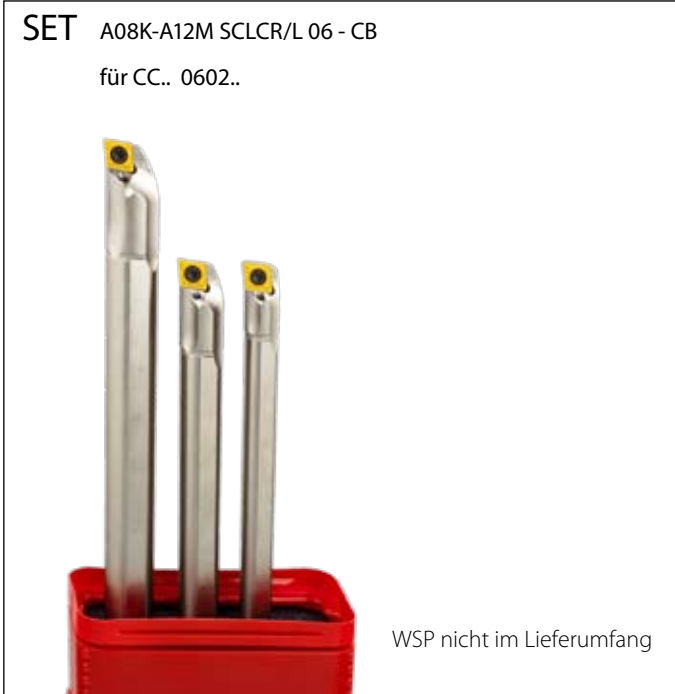

Bezeichnung / Set	bestehend aus:	EUR/ Set
Set A08K-A12M SCLCR/L 06 - CB	1X A08K SCLCR/L 06 - CB 1X A10K SCLCR/L 06 - CB 1X A12M SCLCR/L 06 - CB	162,00
Set A10K-A12M SDUCR/L 07 - CB	1X A10K SDUCR/L 07 - CB 1X A12M SDUCR/L 07 - CB	110,00

Bezeichnung / Einzelwerkzeug	Maße [mm]									Ersatzteile				EUR/ Stück Piese
	D _{min}	D ₁	H	L ₁	L ₂	f	L ₅	L ₆						
A08K SCLCR/L 06 - CB	10	8	7	125	16	5	20	17	48.24.107 4,70	-	-	56.33.612 (T08) 4,70	58,00	
A10K SCLCR/L 06 - CB	12	10	9	125	20	6	25	21					59,90	
A12M SCLCR/L 06 - CB	14	12	11	150	24	7	30	25					62,00	
A10K SDUCR/L 07 - CB	14	10	9	125	20	9		20	48.24.107 4,70	-	-	56.33.612 (T08) 4,70	59,90	
A12M SDUCR/L 07 - CB	16	12	11	150	21	11		24					62,00	

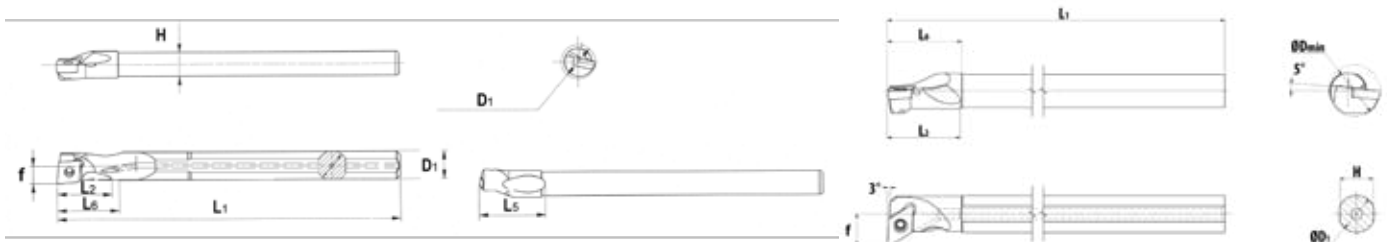

Kleinstbohrstangen

Microbore (ab from Dmin 5mm)

VHM-Bohrstangen

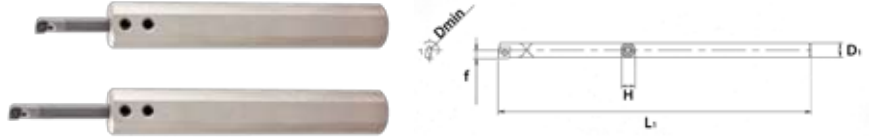

Bezeichnung	Wendeplatte	Maße [mm]					Ersatzteile		EUR/Stück Piece
		Dmin	D1	H	L1	f			
E04G SCLCL/R 0305	CCET 0301	5	4	3.8	90	2.5	48.24.142 5,70	75.20.621 (T06) 5,00	115,50
E05H SCLCR 0306		6	5	4.4	100	3.0			118,30
E06J SCLCL 0307		7	6	5.7	110	3.5			124,20
E06J SCLCL/R 0407	CCET 0401	7	6	5.7	110	3.5	48.24.143 7,05		124,20
E07K SCLCR 0408		8	7	6.5	120	4.0			133,00

Wendeplatten

Bezeichnung	Wendeplatten	TM 5130 (M30C) Niro
		EUR/Stück Piece
CCET 03 01 02 L		14,70
CCET 03 01 02 R		(14,70)
CCET 04 01 02 L		14,70
CCET 04 01 02 R		(14,70)



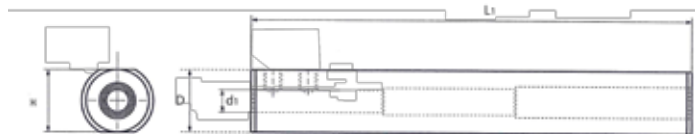



Schafthülsen



Bezeichnung	Maße				Ersatzteile		EUR/Stück Piece
	ØD	Ød1	H	L1			
SH 0416	16	4	14	100	32.35.101 5,10	48.12.605 (SW2) 1,55	58,30
SH 0516		5					

Aluminium Wendeplatten

ALU - Wendeplatten zum Drehen - positiv









Wendeplatte n	Sorte	TK 1210 (K10)	TK 5310 (K10C) Saphitec	TK 5710 (K10C) Goldtec	TP 5345 (P45C)
	Anwendung	Aluminium	HRSA GFK CFK	Sonder- legierungen	Niro Stahl
	Bezeichnung	EUR/Stück Piece	EUR/Stück Piece	EUR/Stück Piece	EUR/Stück Piece
 TP 5345	CCGT 06 02 02 -ALX	6,20	8,80	7,80	14,00
	06 02 04 -ALX				7,80
	09 T3 02 -ALX	7,40	10,30	9,30	9,30
	09 T3 04 -ALX				-
	09 T3 08 -ALX				-
	12 04 02 -ALX	8,20	(11,30)	10,30	-
	12 04 04 -ALX		11,30		10,30
	12 04 08 -ALX		-	-	
 TK 5710	DCGT 07 02 02 -ALX	6,40	8,80	7,80	7,80
	07 02 04 -ALX				
	11 T3 02 -ALX	7,40	10,20	9,20	16,20
	11 T3 04 -ALX				9,20
	11 T3 08 -ALX				9,20
 TK 1210	RCGT 10 03 MO -ALX	9,70	(11,60)	10,60	-
	12 04 MO -ALX	9,90	(13,50)	12,50	-
 TK 5710	SCGT 09 T3 04 -ALX	7,40	10,20	9,20	-
	09 T3 08 -ALX		(10,20)		
	12 04 04 -ALX	8,10	11,30	10,30	-
	12 04 08 -ALX		(11,30)		
 TK 5310	TCGT 11 02 02 -ALX	6,50	(9,10)	8,10	-
	11 02 04 -ALX				
	11 02 08 -ALX				
	16 T3 04 -ALX	8,20	(11,20)	10,20	-
	16 T3 08 -ALX				
 TK 1210	VBGT 11 03 02 -ALX	(7,90)	-	-	-
	11 03 04 -ALX				
	16 04 04 -ALX	8,90	(13,60)	12,60	-
	16 04 08 -ALX				
 TP 5345	VCGT 11 03 02 -ALX	8,00	10,70	9,70	9,70
	11 03 04 -ALX		(10,70)		-
	11 03 08 -ALX				
	13 03 02 -ALX	8,40	(11,90)	10,90	-
	13 03 04 -ALX				
	16 04 02 -ALX	8,90		11,40	11,40
	16 04 04 -ALX				19,60
	16 04 08 -ALX				
	16 04 12 -ALX				(12,40)
	22 05 30 -ALX	14,00	-	18,60	-

Aluminium Wendeplatten

ALU - Wendeplatten zum Drehen - negativ

Wendeplatte n	Sorte	TK 1210 (K10)	TK 5710 (K10C) Goldtec	TM 5130 (M30C)
	Anwendung	Aluminium	Sonder- legierungen	Niro
	Bezeichnung	EUR/Stück Piece	EUR/Stück Piece	EUR/Stück Piece
 TK 1210	CNGG 12 04 04 -A20	7,80	10,15	10,15
	12 04 08 -A20			
 TK 5710	DNGG 15 06 04 -A20	8,30	10,60	10,60
	15 06 08 -A20			
 TM 5130	WNGG 08 04 04 -A20	7,70	9,60	9,60
	08 04 08 -A20			

ALU - Wendeplatten zum Fräsen

Wendeplatten	Sorte	MK 1110 (K10)	MK 1210 (K10)
	Anwendung	Aluminium	Aluminium
	Bezeichnung	EUR/Stück Piece	EUR/Stück Piece
 APEX 10 03 04 FR -ALX APKT 10 35 PDFR -ALX			9,80
			7,50
 APKT 16 04 02 PDFR -A12 16 04 04 PDFR -A12			8,00
			8,00
 APXT 11 T3 PDFR -AL			10,60
 LNEX 10 06 05 PNR -A11 15 10 08 PNR -A11		16,90	
		21,00	
 SDHT 12 04 AEFN -AL			8,50
 SEHT 12 04 AFFN -AL			8,20
 SEKT 12 T3 AEFN -AL			9,00
 SNEX 12 06 ANN -A11		15,90	
 XNEX 08 06 08 -ALX			20,10

Nicht fündig geworden oder noch Fragen?

Dann sprechen Sie uns an.

Hinweis zum Katalog!

- Preise gültig bis 29.02.2024 bzw. bis auf Widerruf.
- Preise in Klammern= begrenzte Lagerhaltung - auf Anfrage
- Alle angegebenen Preise verstehen sich in € und zzgl. der gesetzlichen Mehrwertsteuer.
- Preisänderungen sowie Änderungen an unseren Erzeugnissen, besonders aufgrund technischer Verbesserungen und Weiterentwicklungen, behalten wir uns ausdrücklich vor.

Alle Abbildungen, Zahlenangaben, etc. sind daher ohne Gewähr!

Nachdruck, auch auszugsweise, nur mit unserer schriftlichen Genehmigung.